

LOCK HARDWARE	
LATCH:	SCHLAGE (J10SOL)
DEADBOLT:	KWIKSET SIGNATURE SERIES (780)

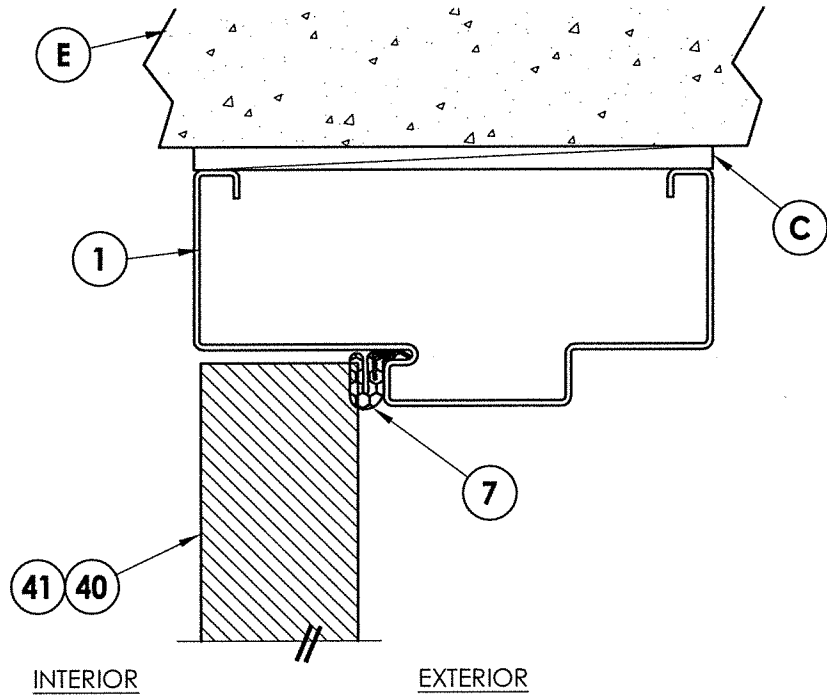

1
4 **VERTICAL CROSS SECTION**
Inswing Shown (Outswing Similar)

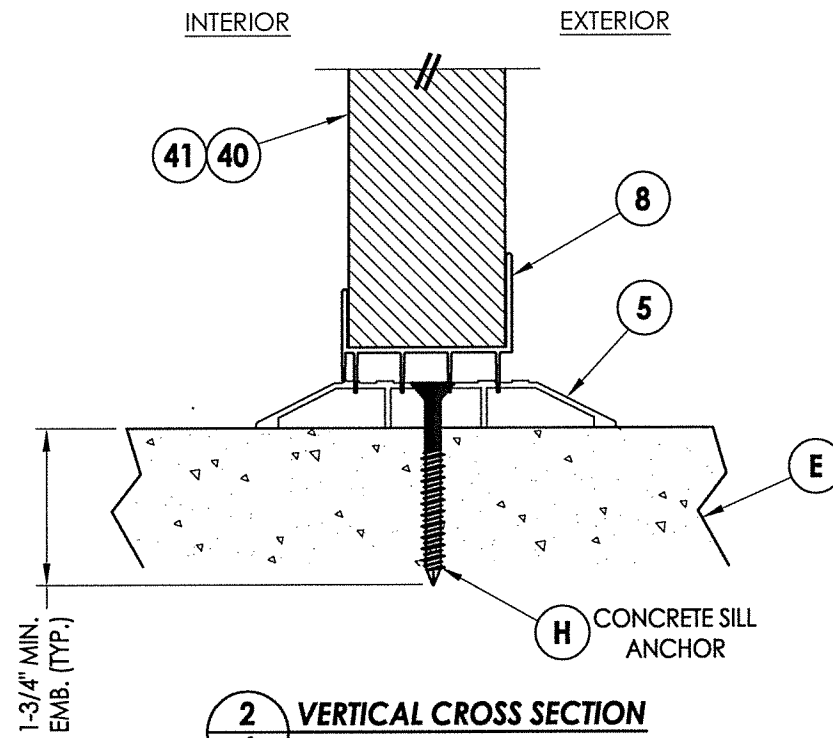

2
4 **VERTICAL CROSS SECTION**

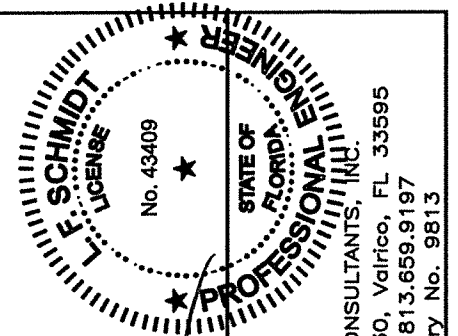

November 4, 2020
 Documents Prepared By:
 Lyndon F. Schmidt
 P.E. No. 43409
 RW BUILDING CONSULTANTS, INC.
 P.O. Box 230, Vairico, FL 33595
 Phone No.: 813.659.9197
 FBPE Registry No. 9813

PRODUCT:	DUNBARTON
PART OR ASSEMBLY:	ELEVATION & VERTICAL CROSS SECTIONS
DATE:	10/13/20
SCALE:	N.T.S.
DWG. BY:	RW
CHK. BY:	LFS
DRAWING NO.:	FL-9231.5
SHEET	4 OF 7

R:\Clients\Dunbarton Permanent\A - Florida Product Approvals\FL-9231 - Swinging Ext Doors - Rediframe PD\C - Drawings\FL 9231 (2020)\FL-9231.5.dwg, 6.3

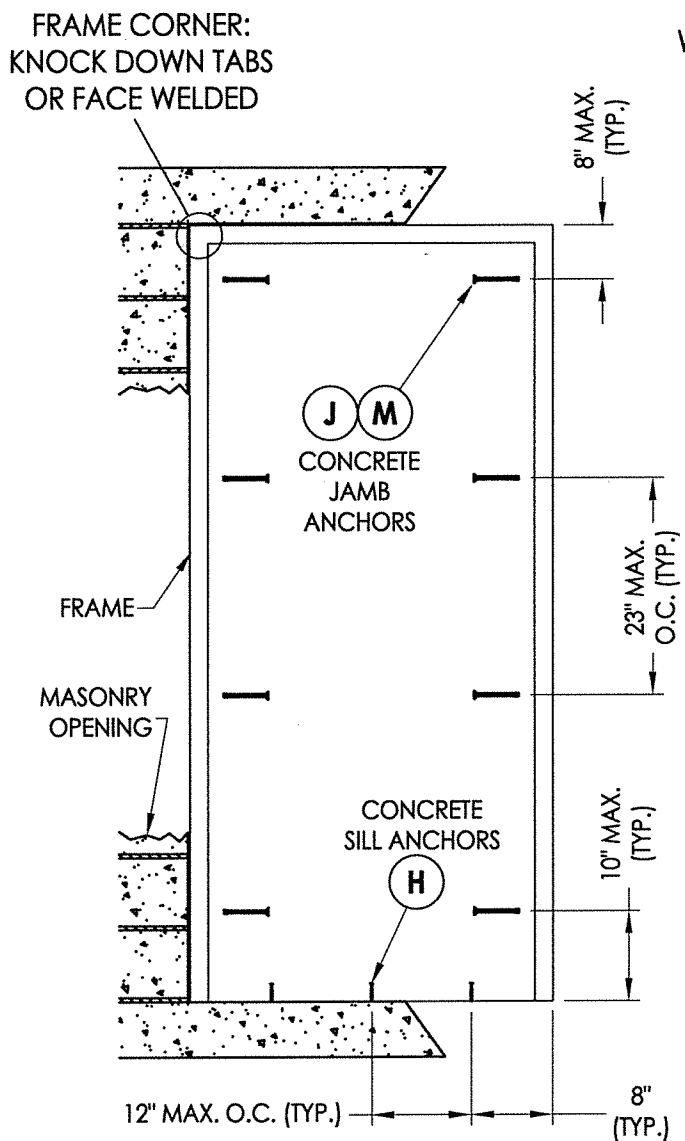

FRAME ANCHORING
Masonry Construction
Concrete Anchors

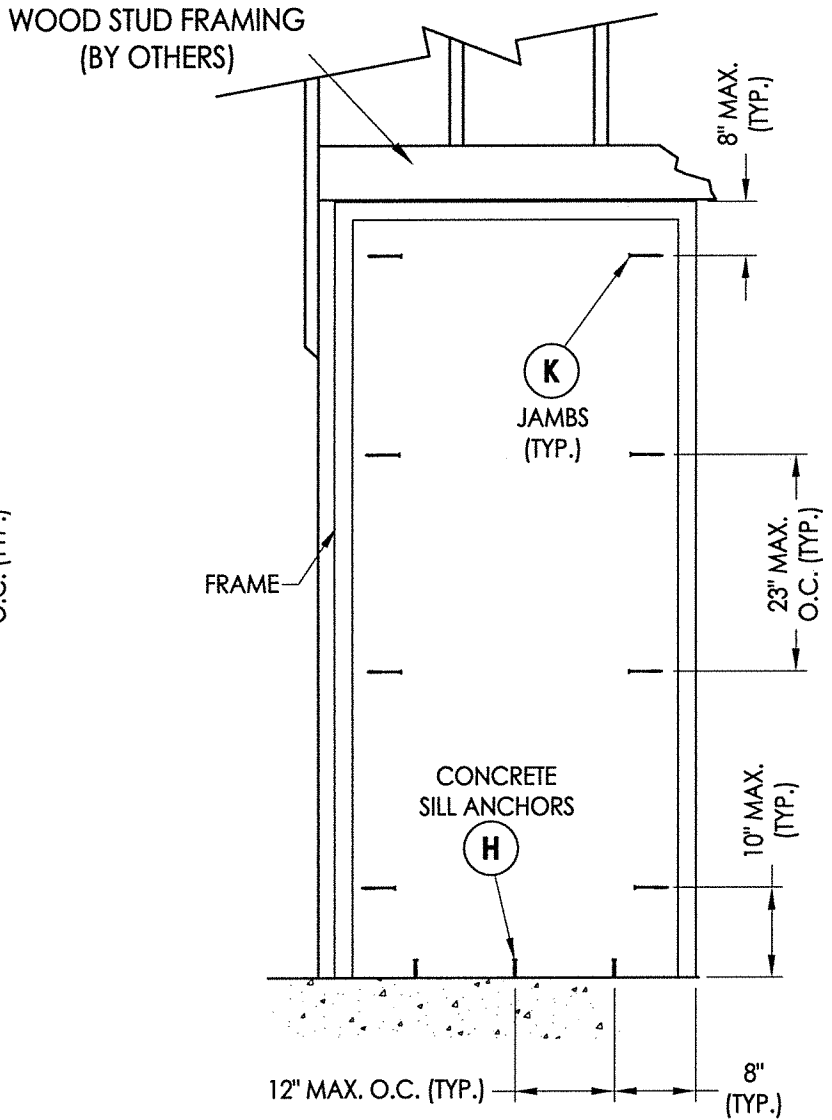

FRAME ANCHORING
Wood Stud

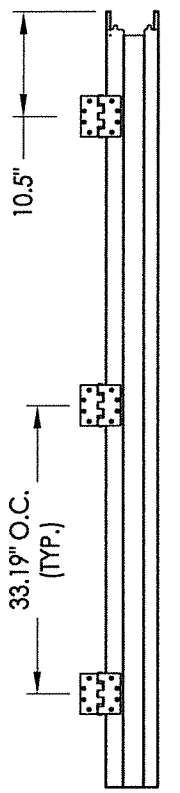

HINGE JAMB

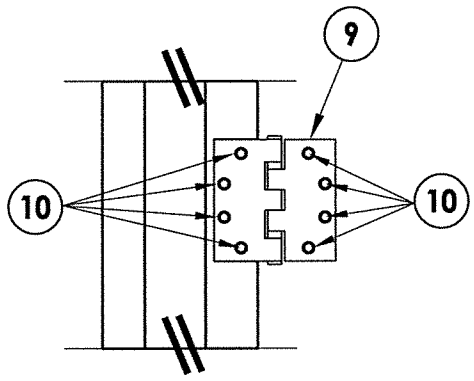

HINGE DETAIL

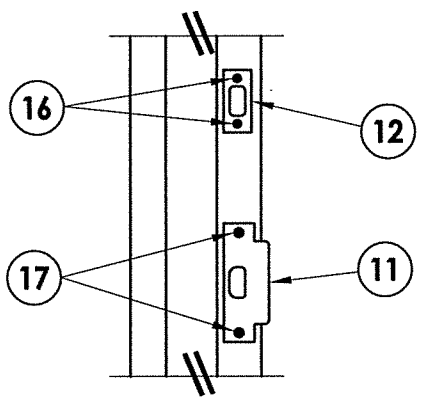

STRIKE DETAIL
Latch & Deadbolt

CONCRETE ANCHOR NOTES:

- Concrete screw locations at the corners may be adjusted to maintain a minimum 1" edge distance to mortar joints. If concrete screw locations noted as "MAX. O.C." must be adjusted to maintain the minimum edge distance to mortar joints, additional concrete screws may be required to ensure the maximum on center dimension is not exceeded.
- Concrete anchor table:

ANCHOR TYPE	ANCHOR LOCATION	ANCHOR SIZE	MANUFACTURER	MIN. EDGE DISTANCE	MIN. EMBEDMENT
CONCRETE ANCHOR SCREW	JAMBS	3/8"	LDT TAPCON® (ITW BUILDEX)	3"	1-1/2"
	SILL	1/4"	TAPCON® (ITW BUILDEX) ULTRACON+® (DeWALT)	2-1/2"	1-3/4"
CONCRETE SLEEVE ANCHOR	JAMBS	3/8"	DYNABOLT SLEEVE ANCHOR® (ITW REDHEAD)	2-1/4"	1-1/2"

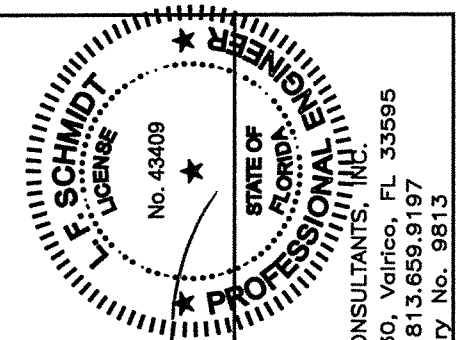

November 4, 2020
 Documents Prepared By:
 Lyndon F. Schmidt
 P.E. No. 43409
 R.W. BUILDING CONSULTANTS, INC.
 P.O. Box 230, Valrico, FL 33595
 Phone No.: 813.659.9197
 FBPE Registry No. 9813

PRODUCT:	DUNBARTON
PART OR ASSEMBLY:	FRAME ANCHORING
NO.	DATE
BY	
REVISIONS	
DATE:	10/13/20
SCALE:	N.T.S.
DWG. BY:	RW
CHK. BY:	LFS
DRAWING NO.:	FL-9231.5
SHEET	6 OF 7

BILL OF MATERIALS		
ITEM #	DESCRIPTION	MATERIAL
B	2X STUD FRAMING (G>= 0.55)	WOOD
C	1/4" MAX. SHIM SPACE	-
E	MASONRY - 3,000 PSI MIN. CONCRETE CONFORMING TO ACI 301 OR HOLLOW BLOCK (GROUT FILLED) CONFORMING TO ASTM C90	CONCRETE
H	1/4" X 2-1/4" PFH CONCRETE SCREW (SEE CONCRETE ANCHOR TABLE)	STEEL
J	3/8" X 5" PFH DYNABOLT SLEEVE ANCHOR (SEE CONCRETE ANCHOR TABLE)	STEEL
K	3/8" X 5" FH LAG SCREW (2-1/8" MIN. EMBEDMENT)	STEEL
M	3/8" X 5" LDT TAPCON CONCRETE SCREW (SEE CONCRETE ANCHOR TABLE)	STEEL
1	HOLLOW METAL FRAME	STEEL
5	ADA THRESHOLD	ALUM
7	WEATHERSTRIP	-
8	DOOR SWEEP	-
9	HINGE 4" X 4"	STEEL
10	#12-24 X 1/2" FH MACHINE SCREW	STEEL
11	LATCH STRIKE PLATE	STEEL
12	DEADBOLT STRIKE PLATE	STEEL
16	#8 X 3/4" FH SCREWS	STEEL
17	#12 X 1" FH SCREWS	STEEL
18	#12 X 1-1/8" PH SMS	STEEL
20	HINGE REINFORCEMENT (12 GA.)	STEEL
30	EXPANSION ANCHOR BRACKET(18 GA)	STEEL
40	STEEL DOOR PANEL (7'-0" DOOR JELD-WEN)	STEEL
41	STEEL DOOR PANEL (7'-0" DOOR MASONITE)	STEEL

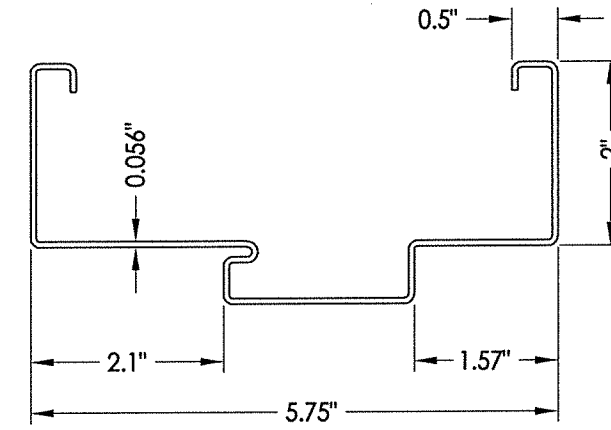

1 HOLLOW METAL FRAME
16 GA. GALV. STEEL

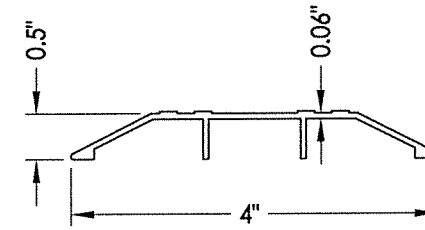

5 ADA THRESHOLD
DLP ISHC

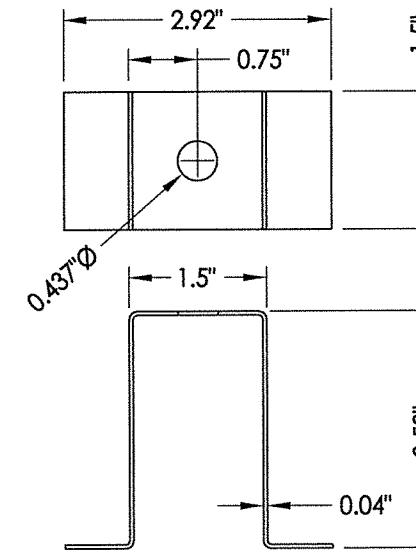

30 EXPANSION ANCHOR
Bracket

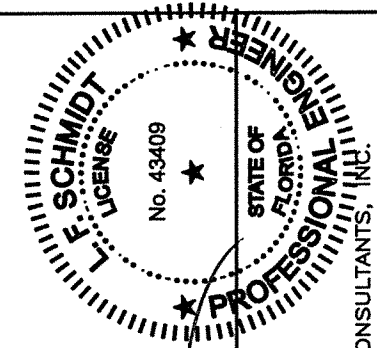

November 4, 2020
 Documents Prepared By:
 Lyndon F. Schmidt
 P.E. No. 43409

November 4, 2020
 Documents Prepared By:
 Lyndon F. Schmidt
 P.E. No. 43409

R.W. BUILDING CONSULTANTS, INC.
 P.O. Box 230, Valrico, FL 33595
 Phone No.: 813.659.9197
 FBPE Registry No. 9813

PRODUCT: DUNBARTON
 PART OR ASSEMBLY: BILL OF MATERIALS & COMPONENTS

NO.	DATE	BY	REVISIONS

DATE: 10/13/20
 SCALE: N.T.S.
 DWG. BY: RW
 CHK. BY: LFS
 DRAWING NO.: FL-9231.5
 SHEET 7 OF 7